

CLEAR STEP AUTOCLOSE 2

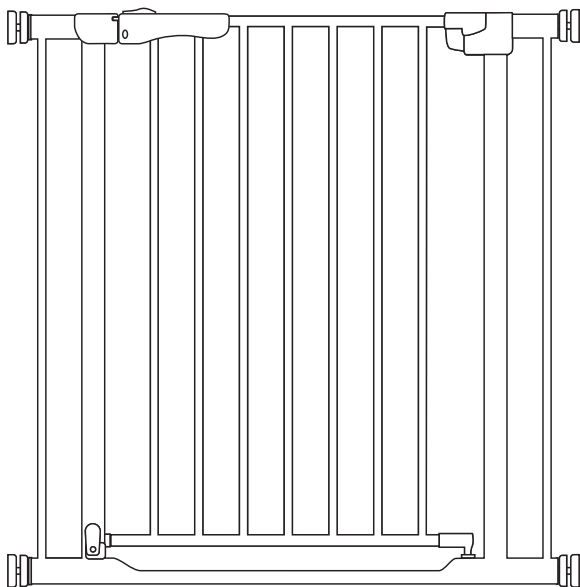

EN	Instructions for use	BS	Upute za korištenje
DE	Gebrauchsanweisung	SR	Uputstvo za upotrebu
FR	Mode d'emploi	RO	Instrucțiuni de utilizare
ES	Manual de instrucciones	MK	Упатство за употреба
IT	Istruzioni per l'uso	BG	Инструкции за употреба
PT	Instruções de utilização	EL	Οδηγίες χρήσης
NL	Gebruiksaanwijzing	TR	Kullanım talimatları
DA	Vejledning til brugen	ET	Kasutusjuhend
FI	Käyttöohjeet	LV	Lietošanas instrukcija
SV	Användningsinstruktioner	LT	Naudojimo instrukcijos
NO	Bruksanvisninger	UK	Інструкція з експлуатації
PL	Instrukcja użytkowania	KA	გამოყენების ინსტრუქცია
CZ	Návod k použití	RU	Инструкции по эксплуатации
SK	Návod na použitie	AR	لإمعة سإلآ اءاءشرا
HU	Használati útmutató	CN	操作说明书
SL	Navodila za uporabo	ZH	操作說明書
HR	Upute za uporabu		

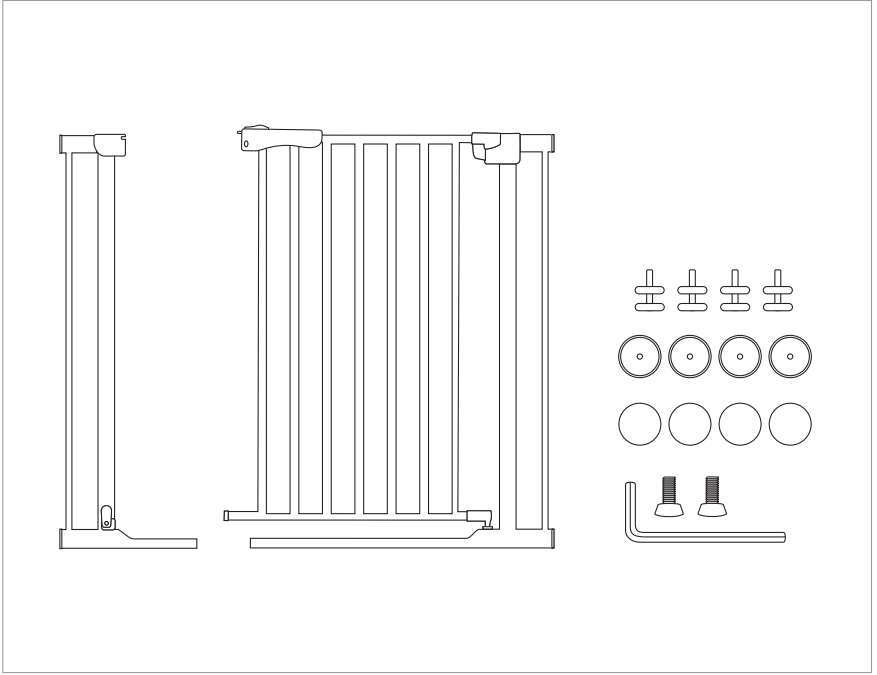

i

Page 19

Page 23

OPTIONS

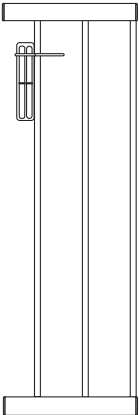
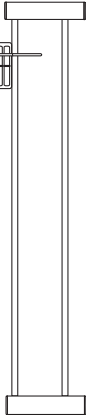

9 cm Extension

21 cm Extension

1

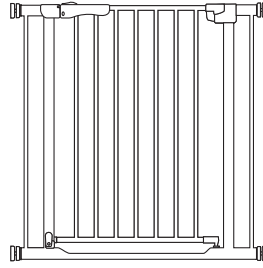
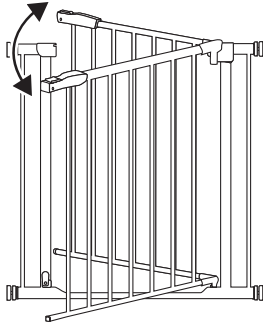

min. 0 - max. 24
months



1

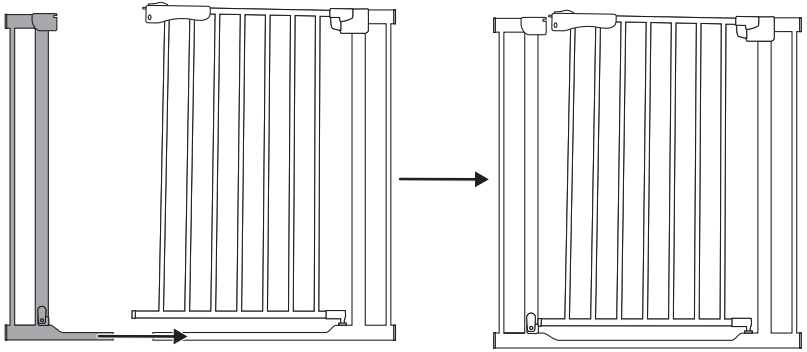

2

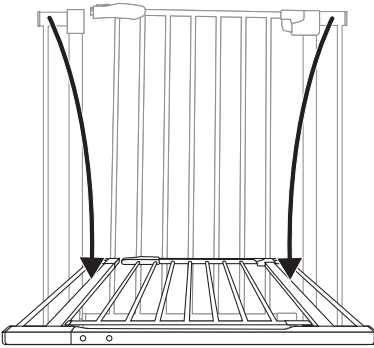

3

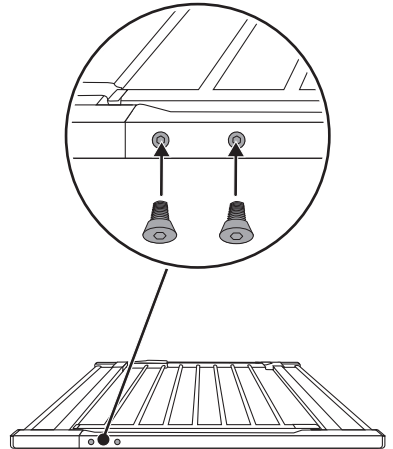



4

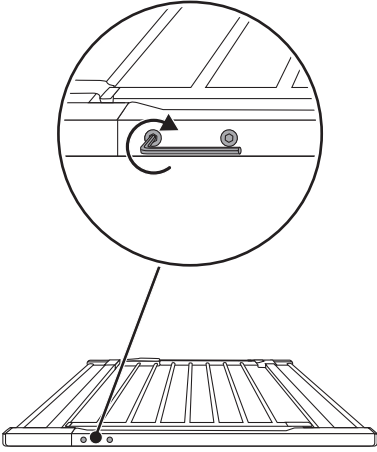

5

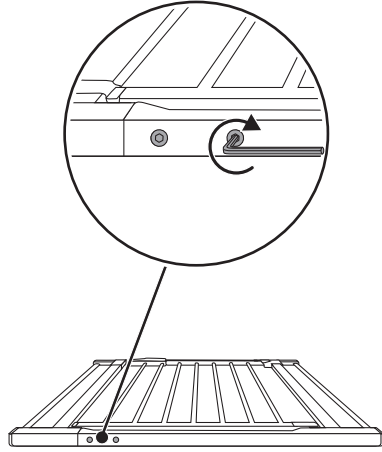

6

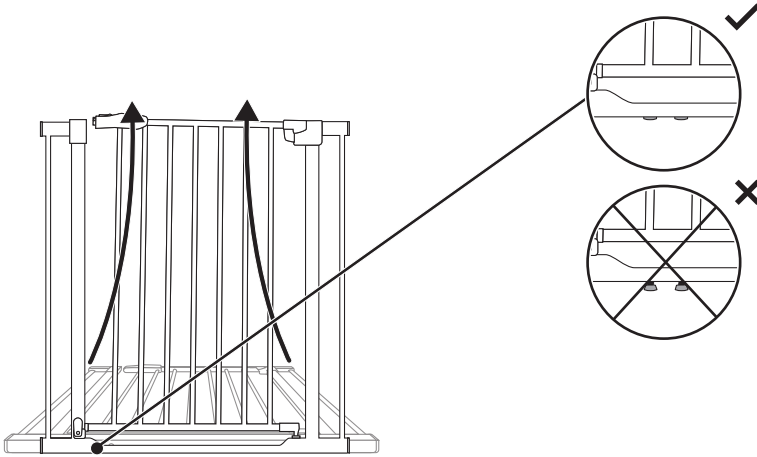

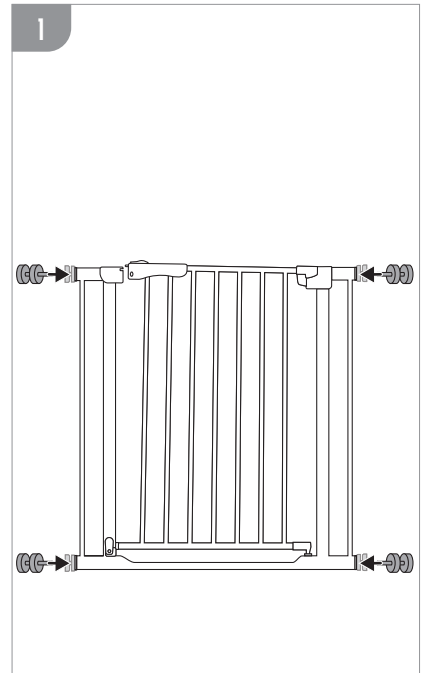
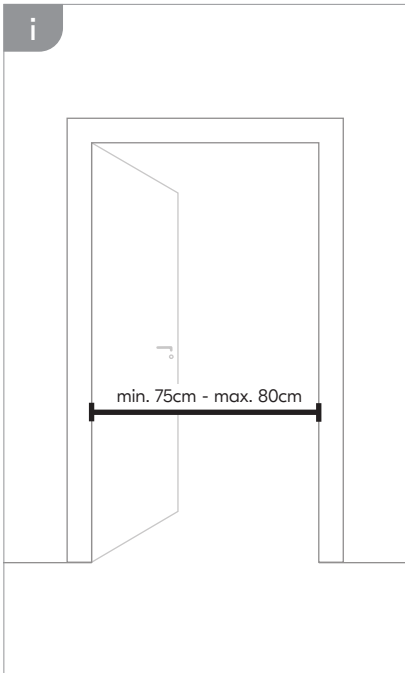
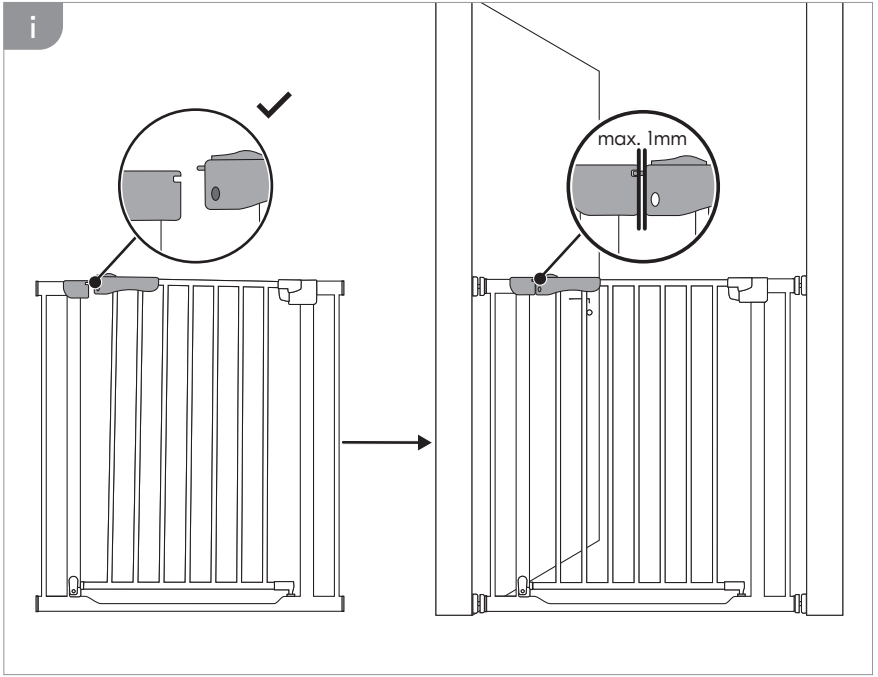



i

✗

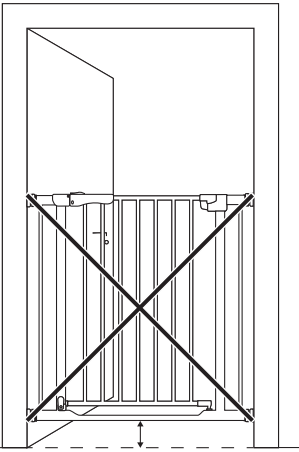

✓

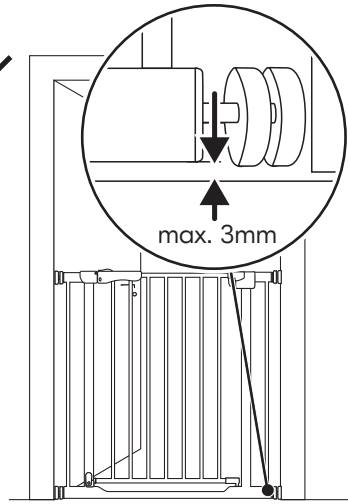

2

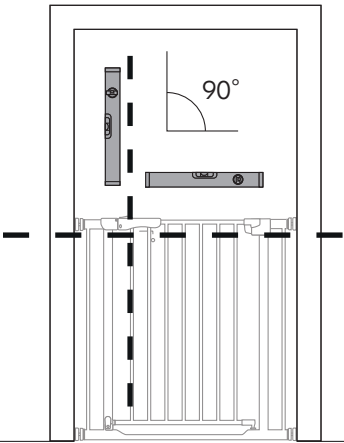

3

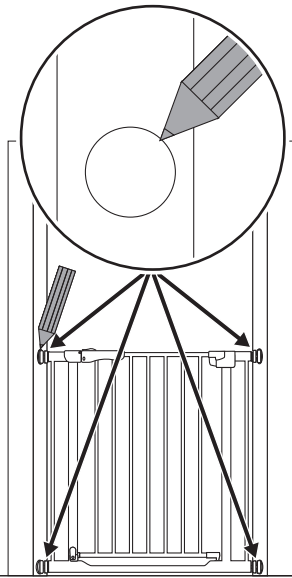

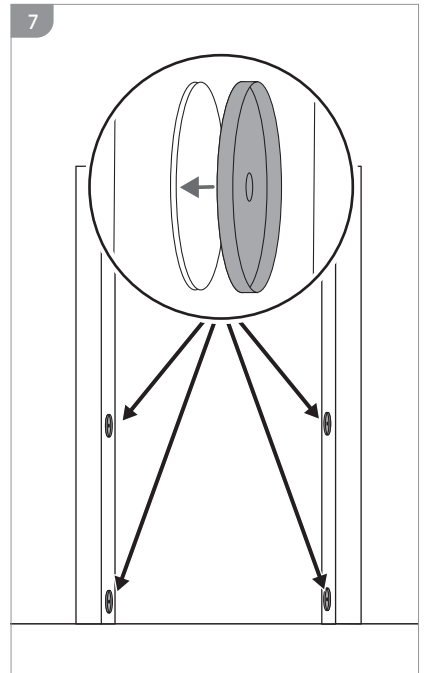
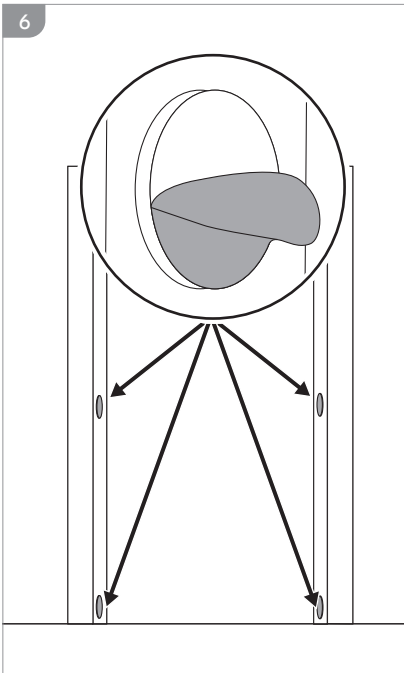
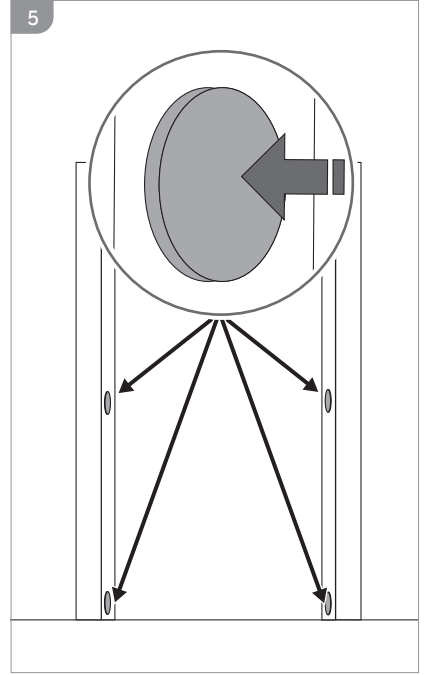
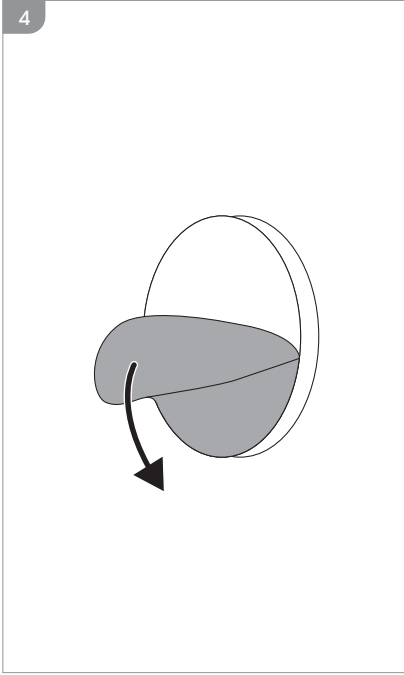



8

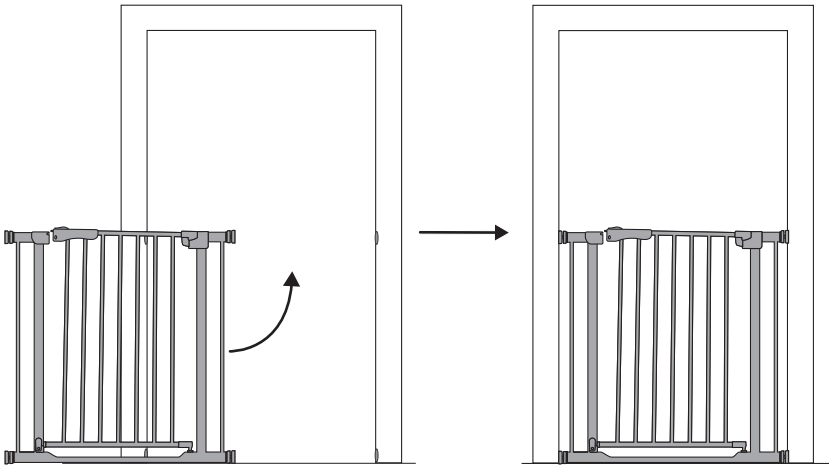

9

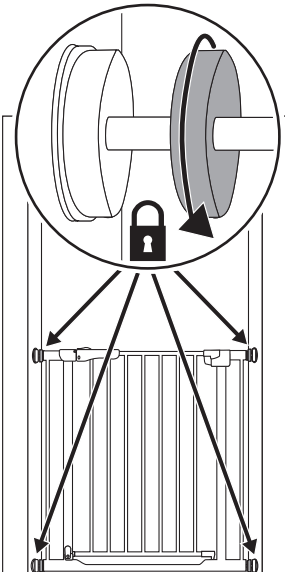

10

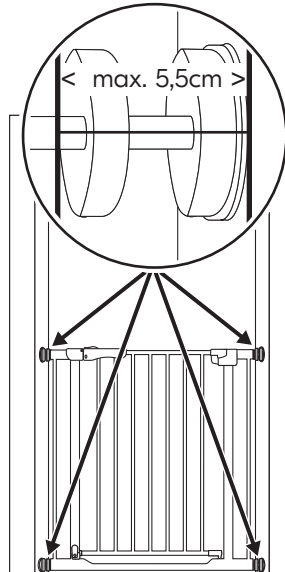

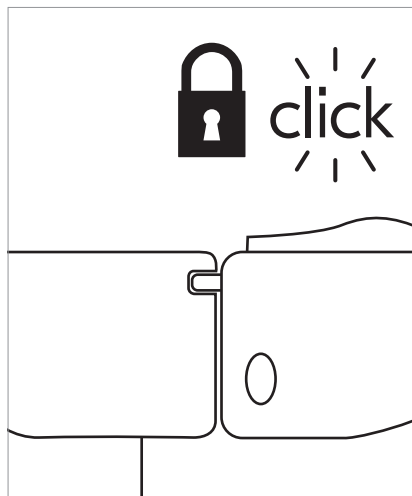
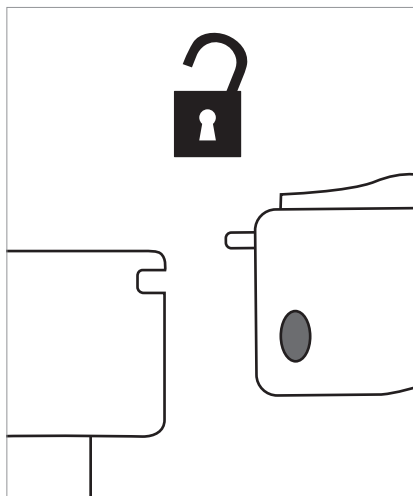

- EN** **WARNING:** The safety gate can be used in a safe way only if the indicator on the door element changes from red (unlocked) ● to green (locked) ○ when closing.
- DE** **WARNUNG:** Das Kinderschutzgitter kann nur dann sicher betrieben werden wenn der Indikator am Türelement beim Schließen von rot (entriegelt) ● auf grün (verriegelt) ○ wechselt.
- FR** **AVERTISSEMENT:** La barrière de sécurité ne peut être utilisée en toute sécurité que si l'indicateur sur l'élément de la porte passe du rouge (déverrouillé) ● au vert (verrouillé) ○ lors de la fermeture.
- ES** **ADVERTENCIA:** La barrera de seguridad para niños sólo se puede operar de forma segura, cuando el indicador en el elemento de la puerta cambia al cierre de rojo (desbloqueado) ● a verde (bloqueado) ○.
- IT** **AVVERTENZA:** Il cancelletto di sicurezza può essere utilizzato sicuramente solo se l'indicatore sul elemento della porta cambia da rosso (aperto) ● a verde (chiuso) ○ durante la chiusura.
- PT** **AVISOS:** A barreira de segurança para crianças só funciona de forma segura, quando o indicador do elemento da porta, ao fechar, muda de vermelho (desbloqueado) ● a verde (bloqueado) ○.
- NL** **WAARSCHUWING:** Het trappenhekje is alleen veilig te gebruiken wanneer de indicator aan het handvat, bij het sluiten van het hekje, van rood (ontgrendeld) ● naar groen (vergrendeld) ○ springt.
- DA** **ADVARSEL:** Børnegitter er først lukket korrekt hvis indikatoren ved døren skifter fra rød (låst op) ● til grøn (låst) ○ når døren lukkes.
- FI** **VAROITUS:** Lasten turvaporattia voi käyttää vain, kun ovi-elementissä oleva ilmaisin vaihtaa sulkiessa punaisesta (auki) ● vihreäksi (lukossa) ○.
- SV** **WARNING:** Barngrinden är endast ett säkert skydd när den visuella indikatorn i grinddelen växlar från röd (öppen) ● till grön (stängd) ○ vid stängning.
- NO** **ADVARSEL:** Beskyttelsesgitteret kan kun brukes sikkert når indikatoren på dørelementet skifter fra rødt (låst opp) ● til grønt (låst) ○ ved lukking.
- PL** **OSTRZEŻENIE:** Bramka zabezpieczająca działa prawidłowo tylko wtedy, gdy znacznik na drzwiach przy zamykaniu zmienia kolor z czerwonego (odblokowane) ● na zielony (zablokowane) ○.
- CZ** **UPOZORNĚNÍ:** Dětská bezpečnostní zábrana svoji bezpečnostní funkci plní pouze tehdy, jestliže se kontrolka na dveřích při jejich uzavření změní z červené (odemknuto) ● na zelenou (uzamčeno) ○.

- SK** **UPOZORNENIE:** Detská bezpečnostná zábrana svoju bezpečnostnú funkciu plní iba vtedy, ak sa kontrolka na dverách pri ich uzatvorení zmení z červenej (odomknuté) ● na zelenú (zamknuté) ○.
- HU** **FIGYELMEZTETÉS:** A gyermekvédő rácsot csak akkor lehet biztonságosan használni, ha az ajtórészen található kijelző bezáráskor pirosról (nyitva) ● zöldre (zárván) vált ○.
- SL** **OPOZORILO:** Otroška zaščitna ograjica lahko varno deluje samo, če se indikator na vratnem elementu ob zaprtju spremeni z rdeče (odprto) ● na zeleno (zapahnjeno) ○.
- HR** **UPOZORENJE:** Sigurnosna ograda za djecu može se sigurno upotrebljavati samo ako indikator na elementu vrata tijekom zatvaranja promijeni boju iz crvene (otključano) ● u zelenu (zaključano) ○.
- BS** **UPOZORENJE:** Zaštitna ogradica za vrata može se sigurno koristiti kada se boja indikatora na elementu vrata prilikom zatvaranja promijeni od crvene (deblokirano) ● u zelenu (blokivano) ○.
- SR** **UPOZORENJE:** Zaštitna ogradica za vrata može bezbedno da se koristi kada se boja indikatora na elementu vrata prilikom zatvaranja promeni od crvene (deblokirano) ● u zelenu (blokivano) ○.
- RO** **AVERTISMENT:** Bariera de securitate pentru copii poate fi utilizată în siguranță numai dacă la închiderea elementului-portiță indicatorul de la acesta își schimbă culoarea de pe roșu (deblocat) ● pe verde (blocat) ○.
- МК** **ПРЕДУПРЕДУВАЊЕ:** Оградата на детското креветче ќе може безбедно да се користи само тогаш кога сијаличката на индикаторот на вратичката при затворање од црвено (отворено) ● ќе се смени во зелено (затворено) ○.
- BG** **ВНИМАНИЕ:** Детската заштитна преграда може само тогава сигурно да се използва, когато индикаторът на елемента на вратата при затваряне се смени от червено (отключено) ● на зелено (заклучено) ○.
- EL** **ΠΡΟΕΙΔΟΠΟΙΗΣΗ:** Το κάγκελο ασφαλείας για παιδιά μπορεί να λειτουργήσει με ασφάλεια μόνον, όταν ο δείκτης στο στοιχείο της πόρτας κατά το κλείσιμο αλλάζει από κόκκινο (απασφάλιση) ● σε πράσινο (ασφάλιση) ○.
- TR** **UYARI:** Bebek güvenlik kapısı ancak kapı kısmındaki gösterge kapatma sırasında kırmızıdan ● (kilit açık) yeşile (kilitli) ○ geçtiğinde güvenli şekilde işletilebilir.
- ET** **HOIATUS:** Laste turvaväravat saab ohutult kasutada üksnes siis, kui ukseelemendi indikaator muutub värava sulgemisel punaselt (lukustamata) ● roheliseks (lukustatud) ○.
- LV** **BRĪDINĀJUMS:** Bērnu drošības vārtiņus var droši ekspluatēt vienīgi tad, kad, aizverot tos, indikators pie durvju elementa mainās no sarkana (vaļā) ● uz zaļu (ciet) ○.
- LT** **ĮSPĖJIMAS:** Vaikų apsauginiai varteliai gali būti saugiai naudojami tik tada, kai durų elemento indikatorius uždarius pakelčia spalvą iš raudonos (atidaryti) ● į žalią (uždaryti) ○.
- UK** **УВАГА:** Дитяча захисна решітка може безпечно експлуатуватися тільки в тому випадку, якщо індикатор на елементі двері змінюється при закритті з червоного кольору (не замкнена) ● на зелений колір (замкнена) ○.
- KA** **გაფრთხილება:** საბავშვო დამცავ ჯებინს გამოიყენებთ, დარწმუნდით რომ ჩასაკეტია სწორად არის მორეგული, კერძოდ წითელი ● ფერის ღილაკი ჩაკეტვისას უნდა შეიცვალოს მწვანე ○ ფერით.
- RU** **ВНИМАНИЕ:** Детская защитная решетка может безопасно эксплуатироваться только в том случае, если индикатор на элементе двери меняется при закрытии с красного цвета (не запертая) ● на зеленый цвет (запертая) ○.
- AR** **انتباه:** يمكن استخدام بوابة الأمان بطريقة آمنة فقط إذا تغير المؤشر على عنصر الباب من الأحمر (غير مؤمن) ● إلى الأخضر (مغلق) ○ عند الإغلاق.
- CN** **警告:** 当门护栏的门关上后, 门上的显示胶件必须由红色(没有锁上) ● 转为绿色(已锁上) ○, 才确保门护栏已正确关好并可安全使用.
- ZH** **警告:** 當門護欄的門關上後, 門上的顯示膠件必須由紅色(沒有鎖上) ● 轉為綠色(已鎖上) ○, 才確保門護欄已正確關好並可安全使用.



1

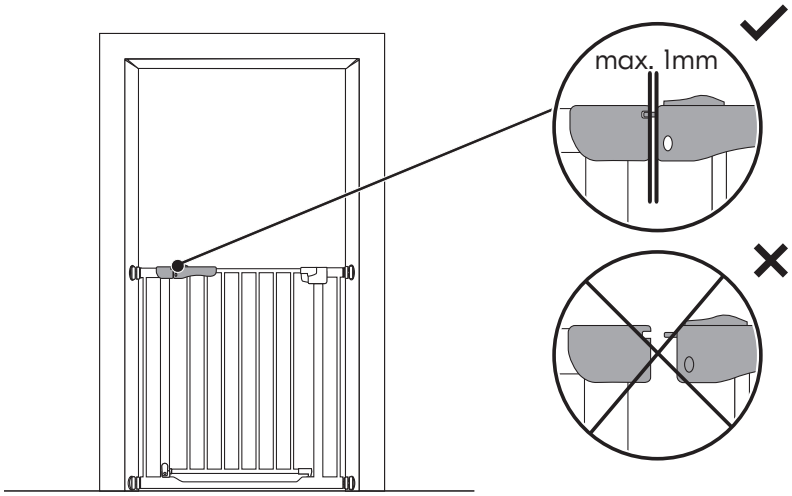

2

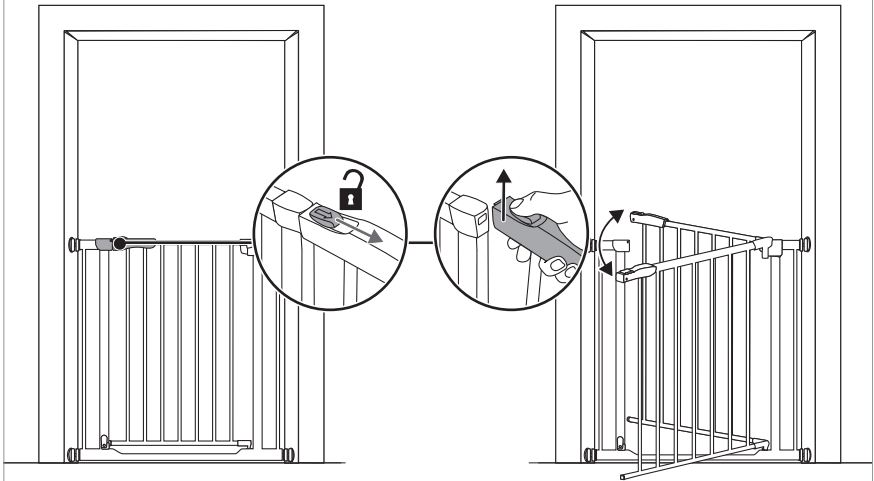



3

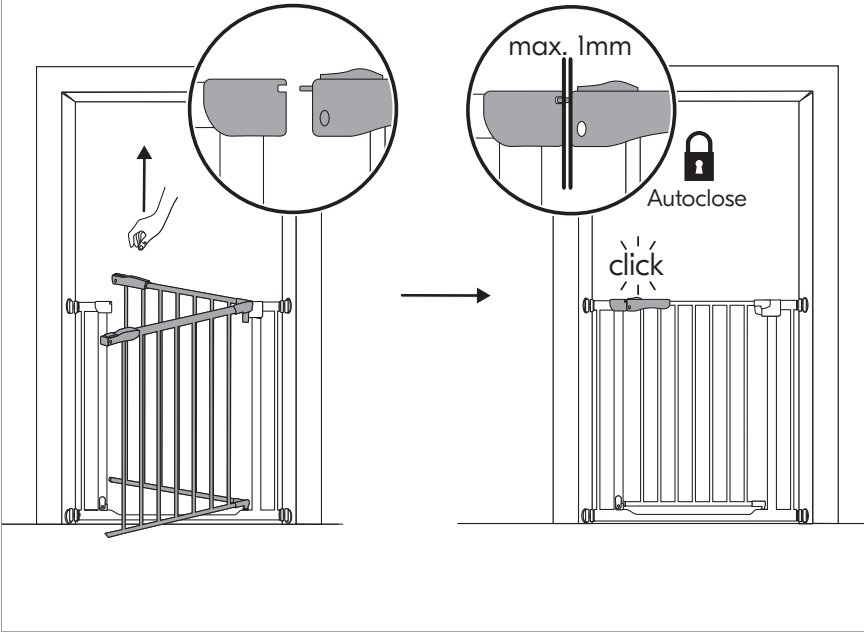

1

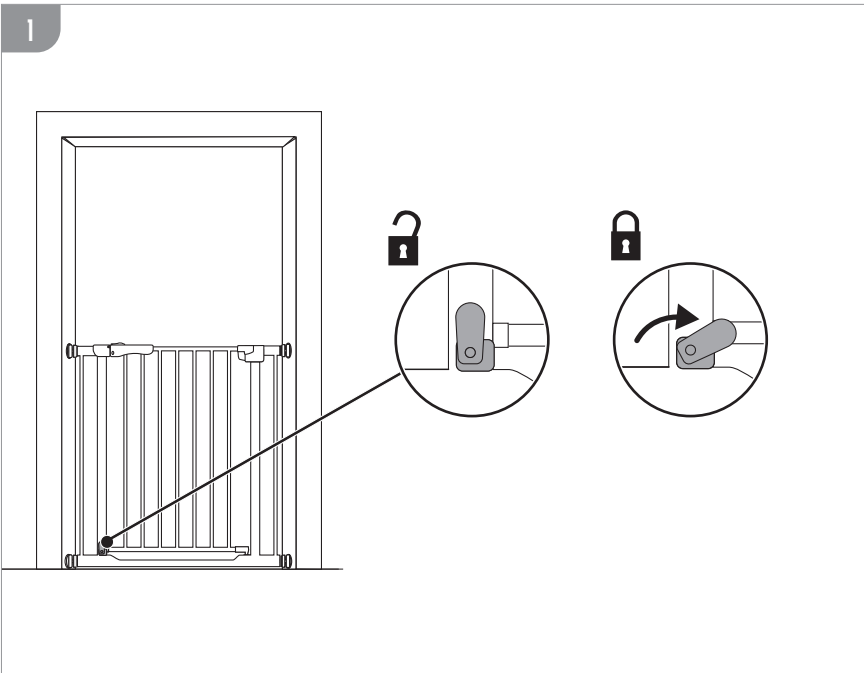



2

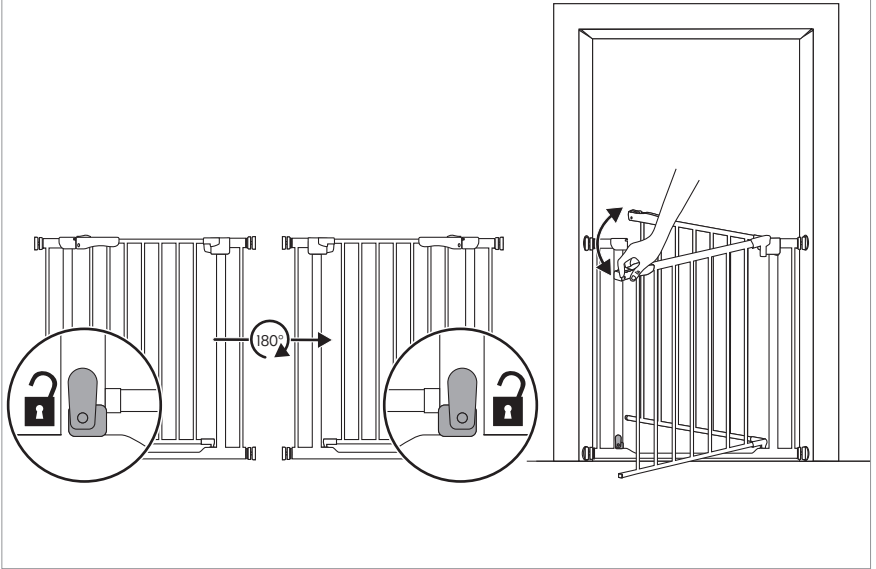

3

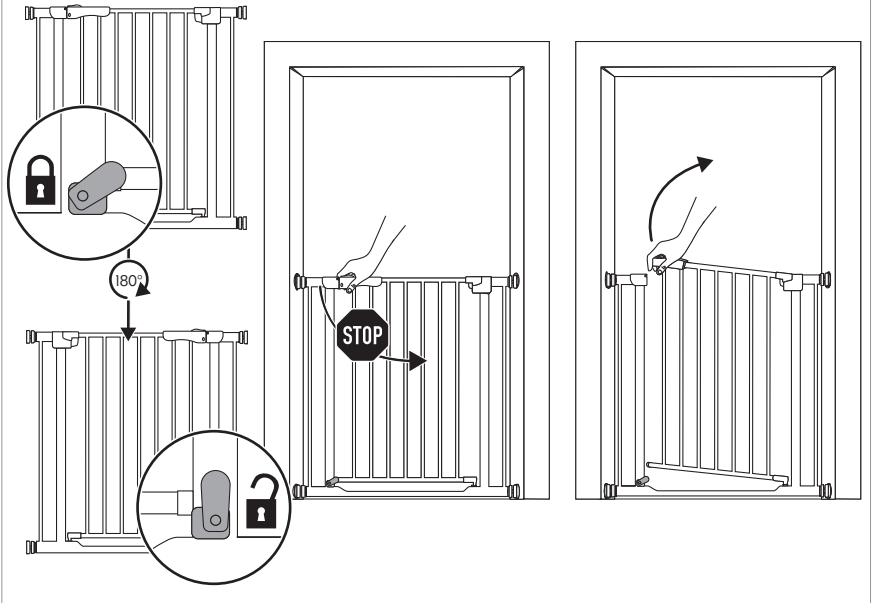



4

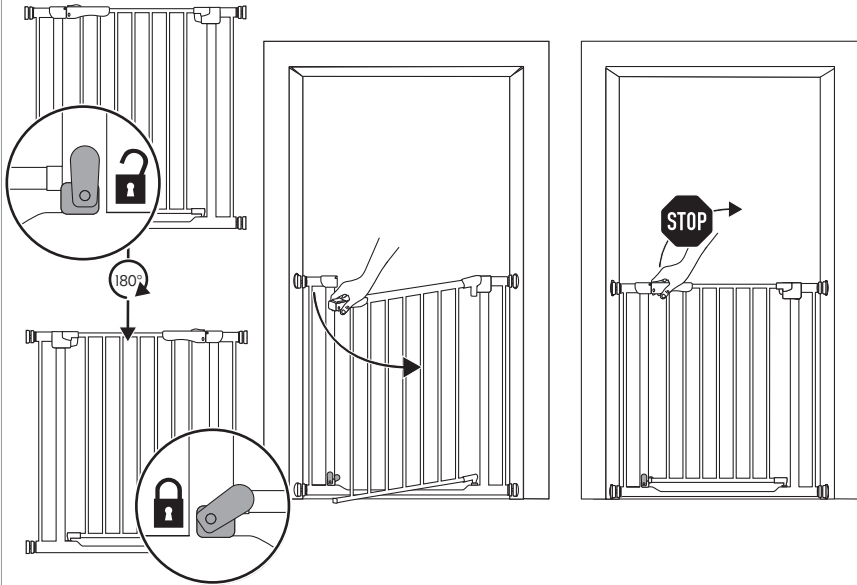

5

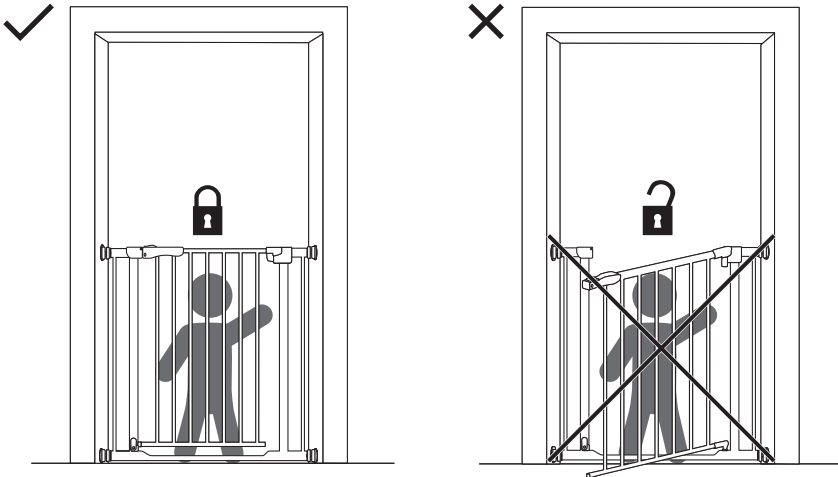

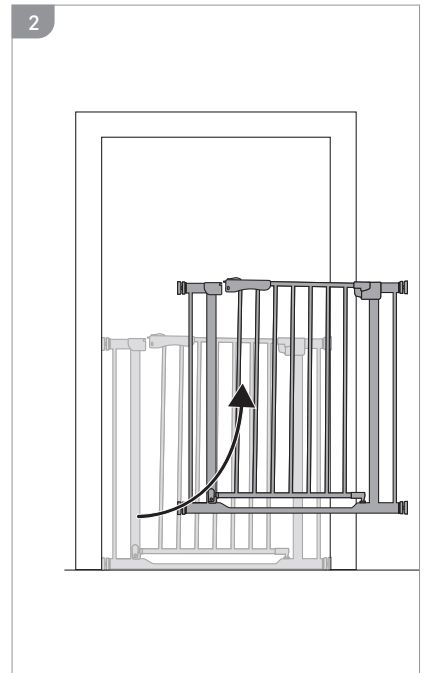
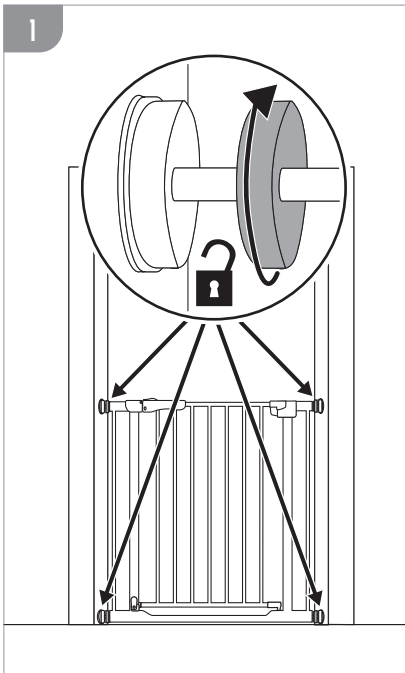
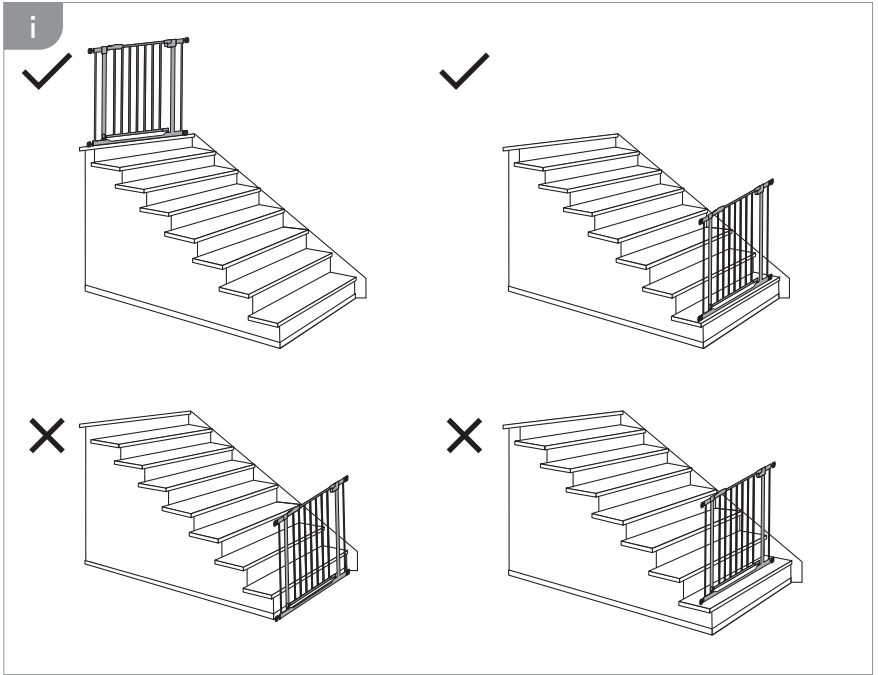

1

OPTION

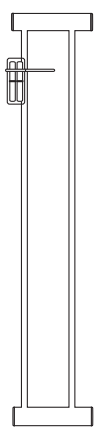

9cm Extension

2

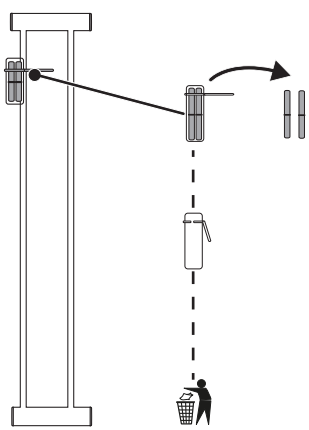

3

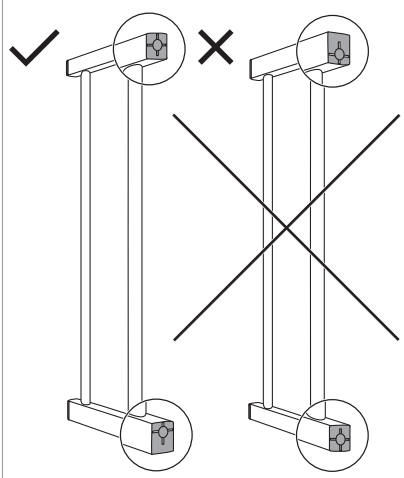

4

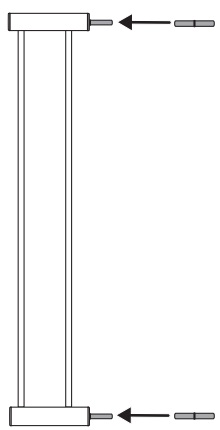

5

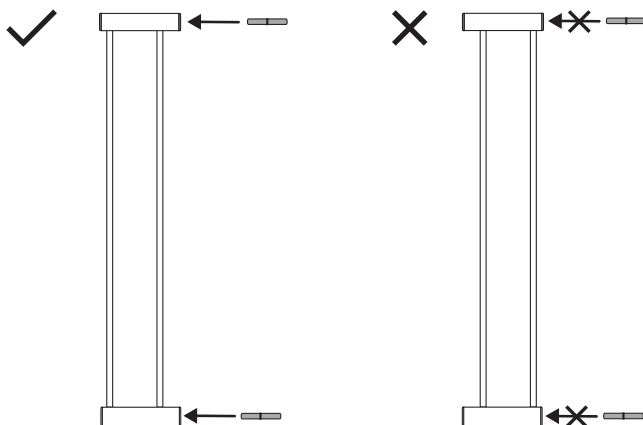

6

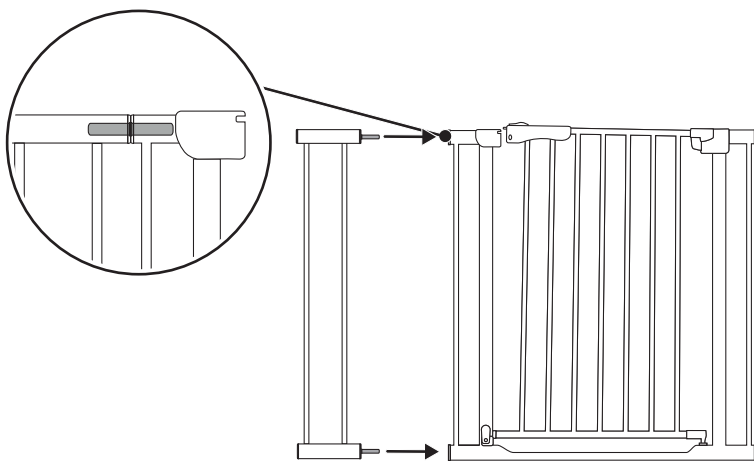

7

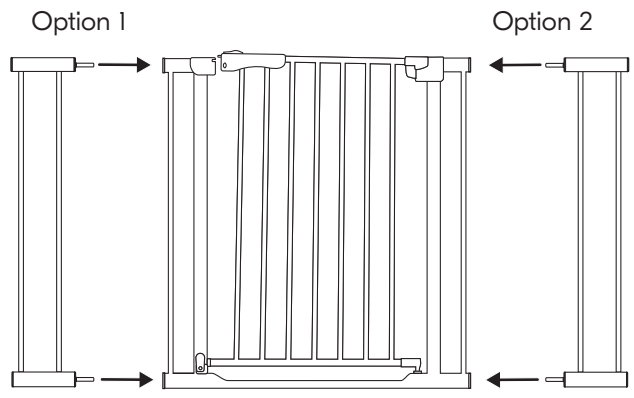

8

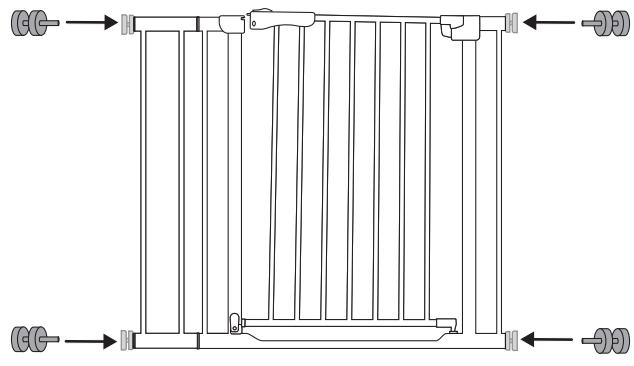

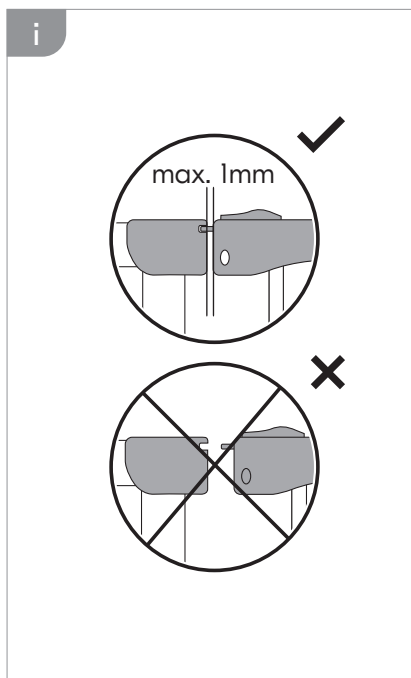
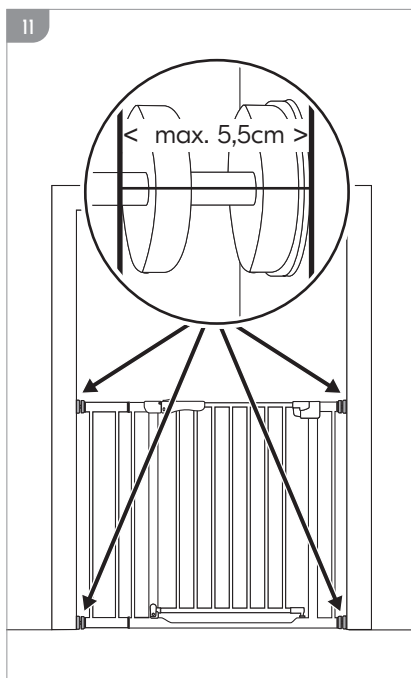
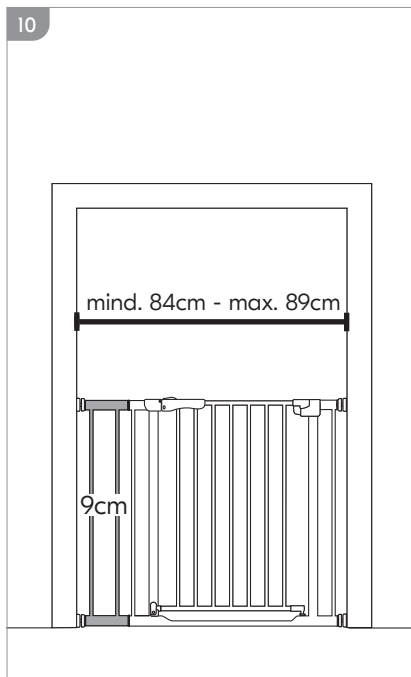
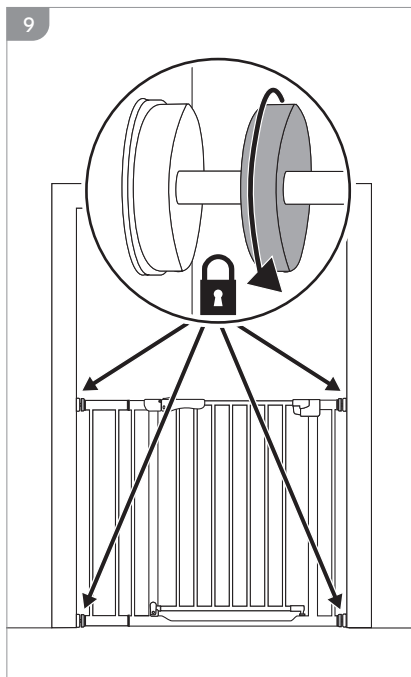

1

OPTION

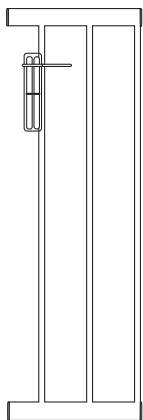

21cm Extension

2

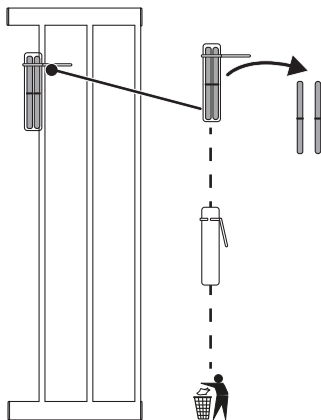

3

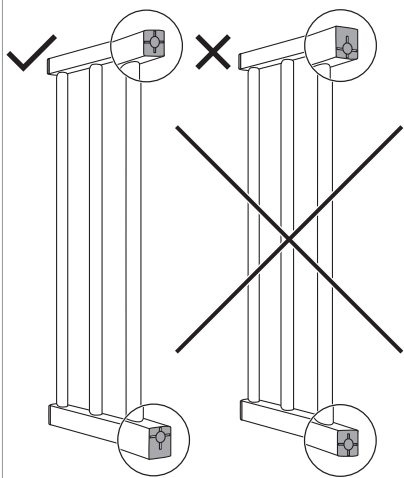

4



5

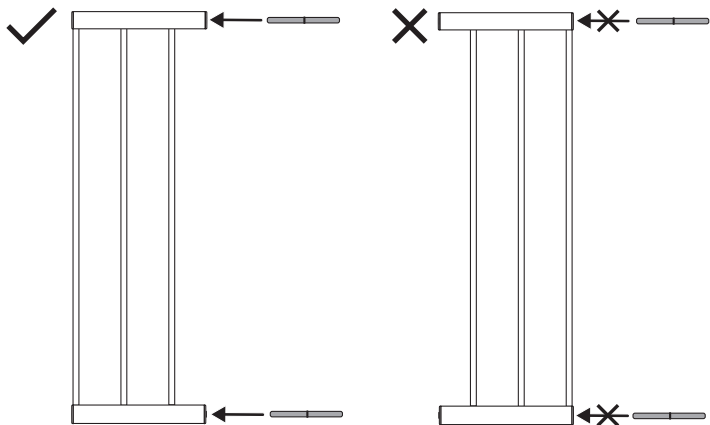

6

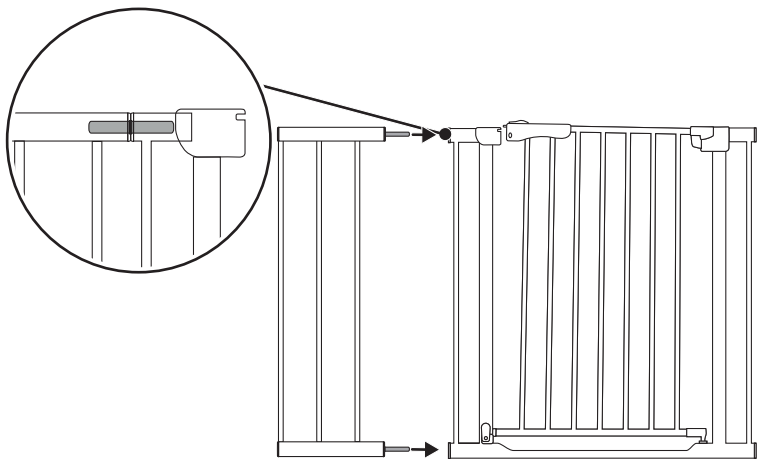

7

Option 1

Option 2

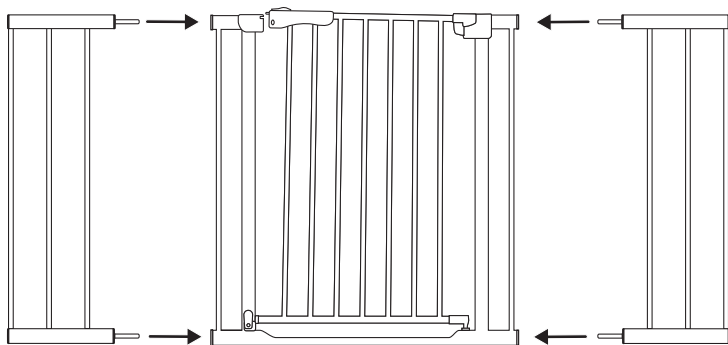

8

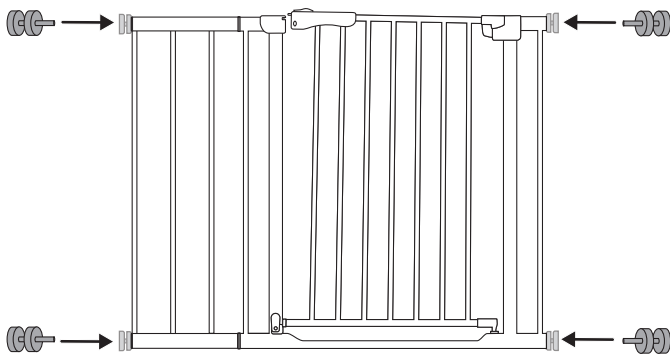

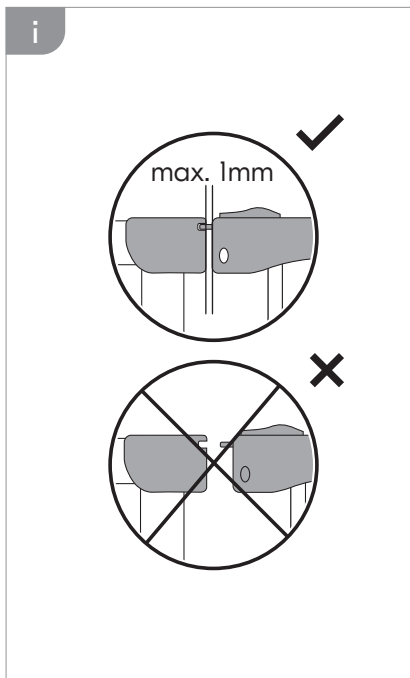
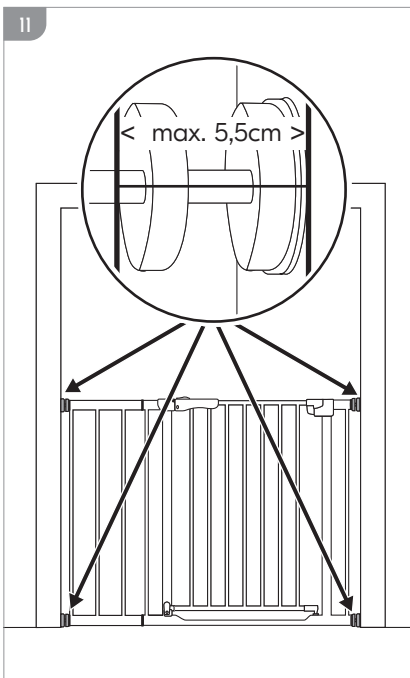
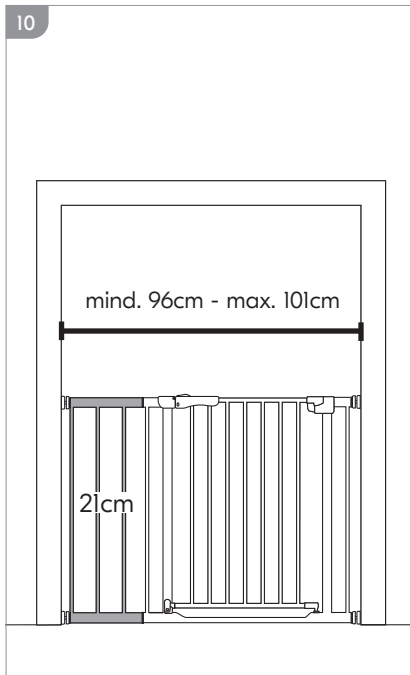
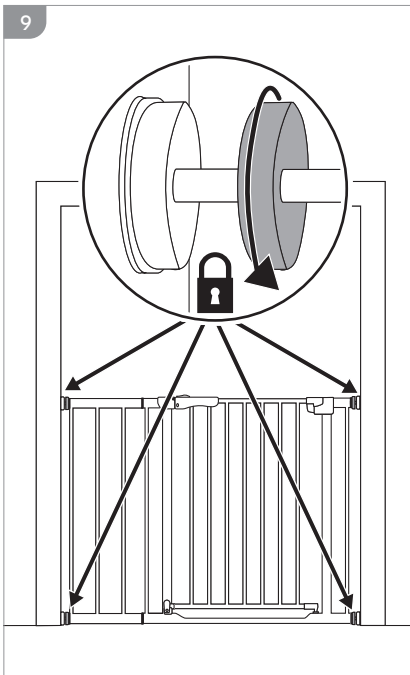

Clear Step Autoclose 2 + Extensions

Clear Step Autoclose 2

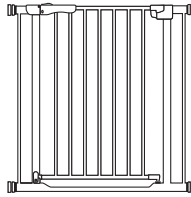

75cm - 80cm

Clear Step Autoclose 2 + 9cm Extension

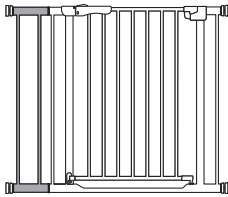

84cm - 89cm

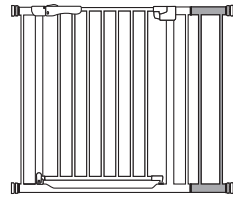

84cm - 89cm

Clear Step Autoclose 2 + 21cm Extension

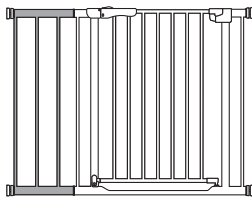

96cm - 101cm

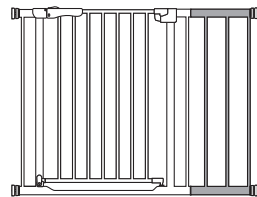

96cm - 101cm

Clear Step Autoclose 2 + Extensions

Clear Step Autoclose 2
+ 9cm Extension
+ 9cm Extension

93cm - 98cm

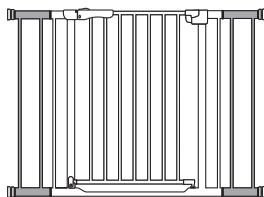

Clear Step Autoclose 2
+ 9cm Extension
+ 21cm Extension

105cm - 110cm

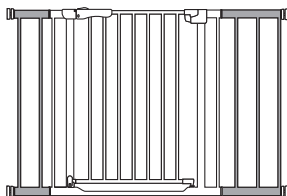

Clear Step Autoclose 2
+ 21cm Extension
+ 9cm Extension

105cm - 110cm

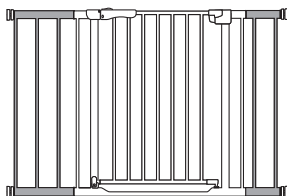

Clear Step Autoclose 2
+ 21cm Extension
+ 21cm Extension

117cm - 122cm

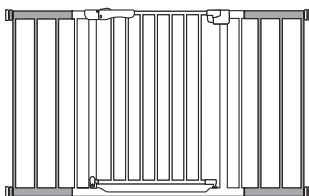

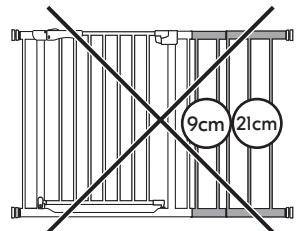
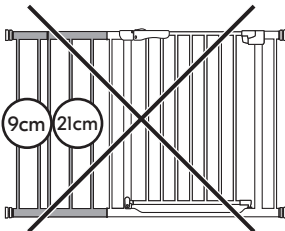
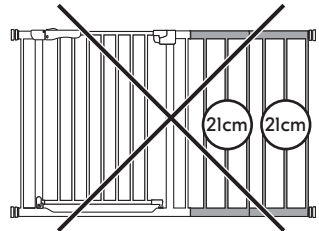
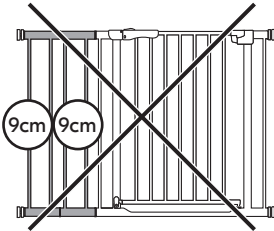
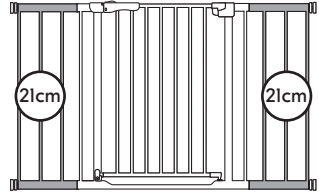
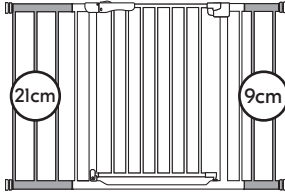
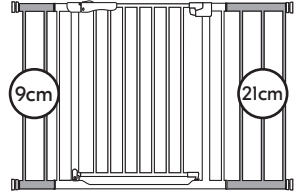
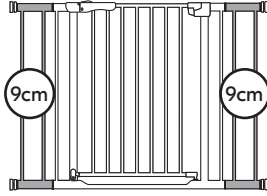



hauck GmbH & Co. KG
Frohnlecher Str. 8
96242 Sonnefeld
Germany

phone: +49 (0)9562 9860
mail: info@hauck.de
web: www.hauck.de

hauck UK Ltd.
Ash Road South
Wrexham Industrial Estate
Wrexham, LL13 9UG, UK

phone: +44 (0)1978 664362
mail: info@hauckuk.com



RACCOLTA CARTA
RACCOLTA DIFFERENZIATA
Verifica le disposizioni
del tuo Comune

